

1103HD MOTORIZED DRAPERY TRACK

Allowance for Draperies Model 1103HD

- Pinch Pleat 1 7/8" to inside bottom of ring
- Ripplefold / Accordiafold 1 7/8" to center of snap

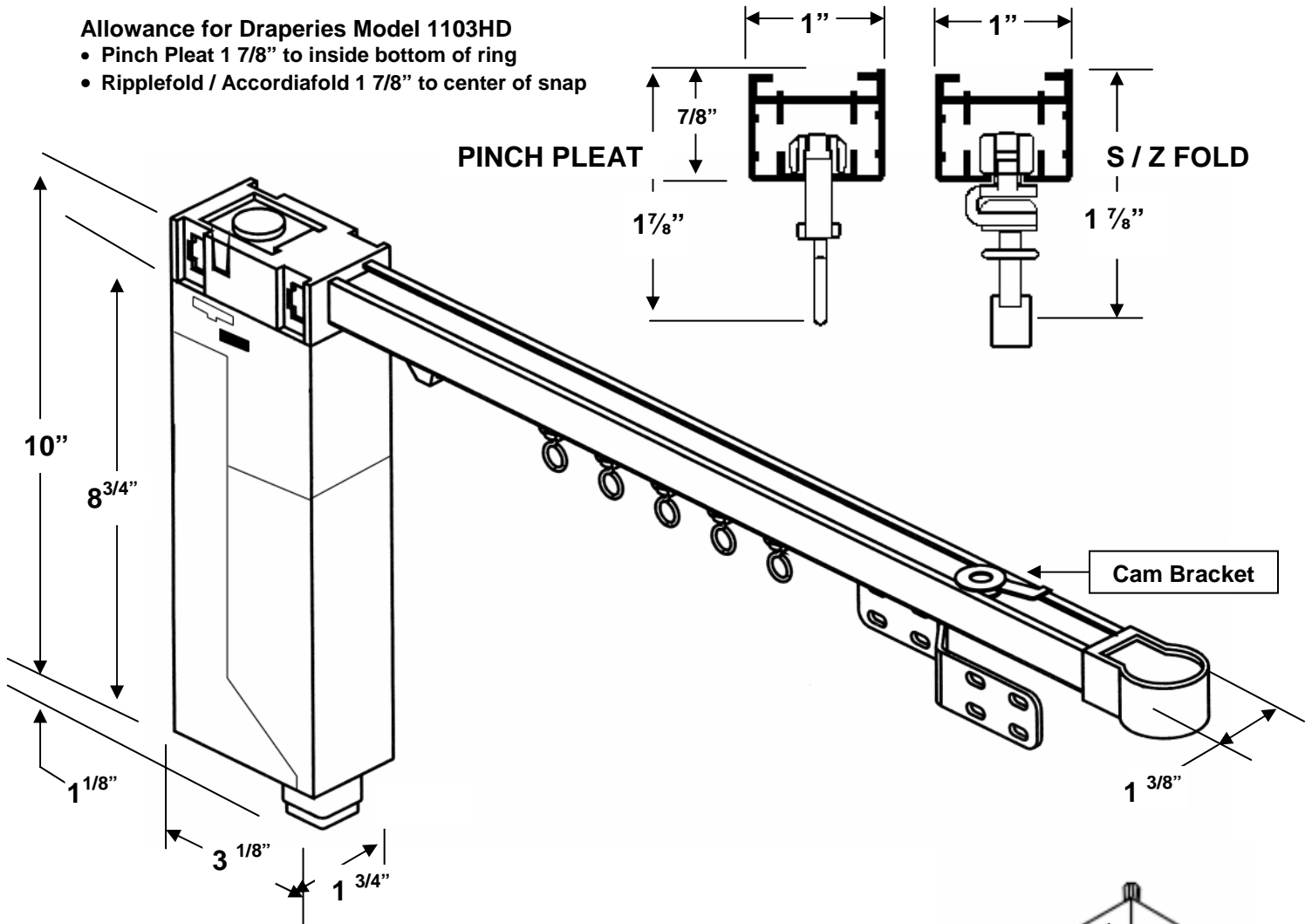

1103HD DRAPERY MOTOR

Built-in dry-contact control interface allows direct access to all Home Automation and Home Theater automated control systems.

Two standard, 4-conductor telephone plug receptacles (jacks) for single or group control. Group control (requires AT464 splitter).

Connection to Home Automation and Home Theater Control Systems via 4-conductor telephone wire.

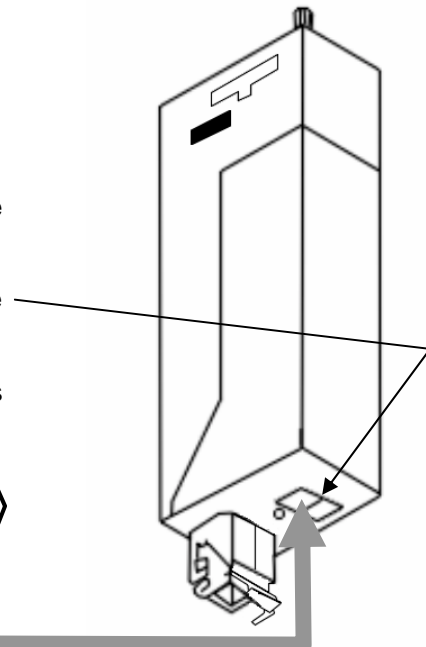
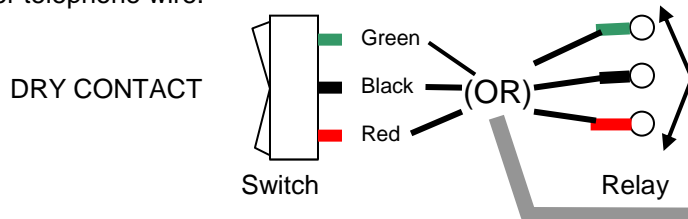

For more information contact:

Am-Source International 1550 Old Rand Road, Unit A Wauconda, IL 60084 Phone: 1.800.876.7367